



S Series

Heavy Duty Slurry Pump • Elastomer and Hard Iron Liners

Applications

The S Series pump is an all-around workhorse that combines high efficiency with long-lasting wear life in a design that has withstood the test of time. Its simple construction lends itself to ease of maintenance, and you won't find lower cost of ownership elsewhere.



Mining & Mineral Processing applications benefit from the slow running speeds of the S Series pumps and their easily replaceable elastomer or white iron liners and impellers. Especially suited for rugged mill discharge with coarse or fine particles.



Chemical Processes often require corrosion resistance in addition to erosion resistance. With a wide variety of white iron metallurgies and multiple natural and synthetic elastomer liner options available, the S Series offers the best pump solution for any chemical process.



Sand & Gravel operations are familiar with the heavy toll that maintenance on slurry pumps can take on a budget. Schurco Slurry® pumps are designed for ease of maintenance, minimizing downtime when standby pumps are not available.

WIDELY FIELDDED APPLICATIONS

Coal Washing • Mill Discharge, Concentrator, Tailings • Flue Gas Desulphurization (FGD)
Sugar Processing • Steel Mills • Oil & Gas (Upstream) • Industrial Applications

Schurco Slurry® Pumps are designed specifically for abrasive pumping of any kind

Technical Specification

The S Series pump design provides ideal duty points from low flows of 10 gallons per minute (GPM) (2.3 cubic meters per hour [m³/hr]) through excess of 18,000 GPM (4,090 m³/hr). Designed to be able to reach heads greater than 250 feet (76 m) in a single pump, these pumps strike the ideal balance between wear-rates and efficiency.

The fully-lined S Series pump is configurable with a wide variety of proprietary metal or elastomer wet-end components as well as a diverse selection of shaft seals, which can be tailored to each specific application.

S Series pumps are designed for slurries through Class IV with appropriate material selection.

S SERIES PUMPS

| Base Model | Bearing Assembly | Nominal Suction x Discharge (inches, [mm]) | Nominal Impeller* Diameter (inches, [mm]) | Solid Sphere Passing, ø* (inches, [mm]) | Impeller* Materials | Liner Materials |
|------------|------------------|--|---|---|---|---|
| 1.5 S 25 | B | 1.5x1 [40x25] | 5.98 [152] | 0.55 [14] | Chrome Iron(s) and Elastomer(s) Available NOTE: Open face, large particle and specialized impellers available upon request Specialty alloys and duplex stainless available in many series | Chrome Iron(s) and Elastomer(s) Available Specialty alloys and duplex stainless available in many series |
| 2 S 40 | B | 2x1.5 [50x40] | 7.24 [184] | 0.75 [19] | | |
| 3 S 50 | C | 3x2 [75x50] | 8.43 [214] | 0.98 [25] | | |
| 4 S 75 | C, D | 4x3 [100x75] | 9.65 [245] | 1.42 [36] | | |
| 6 S 100 | D, E | 6x4 [150x100] | 14.37 [365] | 2.01 [51] | | |
| 8 S 150 | E, F, R | 8x6 [200x150] | 20.08 [510] | 2.48 [63] | | |
| 10 S 200 | F, S | 10x8 [250x200] | 27.01 [686] | 2.99 [76] | | |
| 12 S 250 | F, S, G | 12x10 [300x250] | 30.00 [762] | 3.39 [86] | | |
| 14 S 300 | F, S, G, T | 14x12 [350x300] | 37.99 [965] | 3.54 [90] | | |
| 16 S 350 | G, T | 16x14 [400x350] | 42.01 [1067] | 5.31 [135] | | |
| 20 S 450 | T | 20x18 [500x450] | 53.94 [1370] | 5.12 [130] | | |

*Standard impeller (typically five vane, chrome iron, closed face)

BEARING ASSEMBLY RATINGS

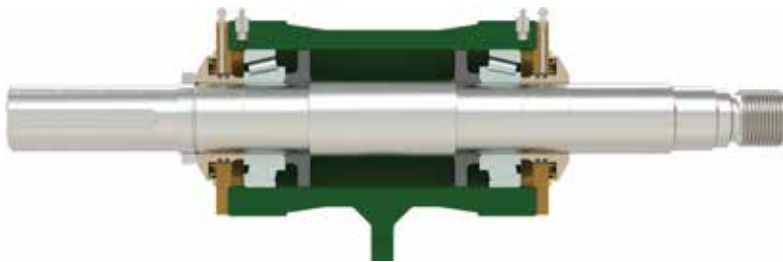

- Grease-lubricated cartridge bearing assembly
- Extended bearing life with oversized shaft diameters and bearings
- Only the highest quality name brand tapered-roller and roller bearings
- Safe and simple single-point impeller adjustment to maintain top efficiency

| Type | Standard (HP [kW]) | High Capacity (HP [kW]) |
|------|--------------------|-------------------------|
| B | 20 [15] | N/A |
| C | 40 [30] | 74 [55] |
| D | 80 [60] | 148 [110] |
| E | 161 [120] | 302 [225] |
| R | 402 [300] | N/A |
| F | 349 [260] | 570 [425] |
| S | 751 [560] | N/A |
| G | 805 [600] | 1207 [900] |
| T | 1609 [1200] | N/A |

S Series Options

SHAFT

Oversized high-strength alloy steel shaft limits deflection during operation

BASE

Robust cast iron base cradles bearing cartridge and allows simple impeller adjustment and pump wet-end support with minimal number of through bolts.

Standard Seal Options

EXPPELLER SEAL ASSEMBLY

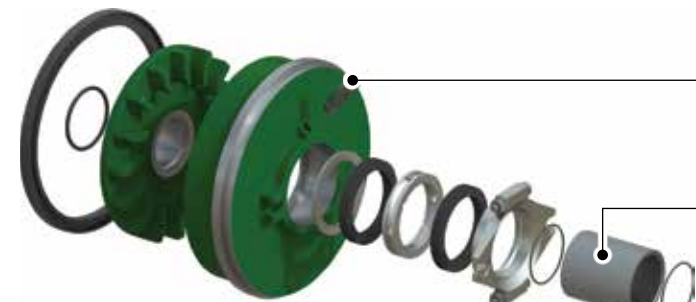

External sealing water avoided in many applications with the expeller seal

GLAND SEAL ASSEMBLY



A hardened, slip-fit, shaft sleeve reduces costs and protects the shaft from wear and corrosion.

Many other application specific seals available – Talk to a Schurco Application Engineer to find out more!

MECHANICAL SEAL ASSEMBLY

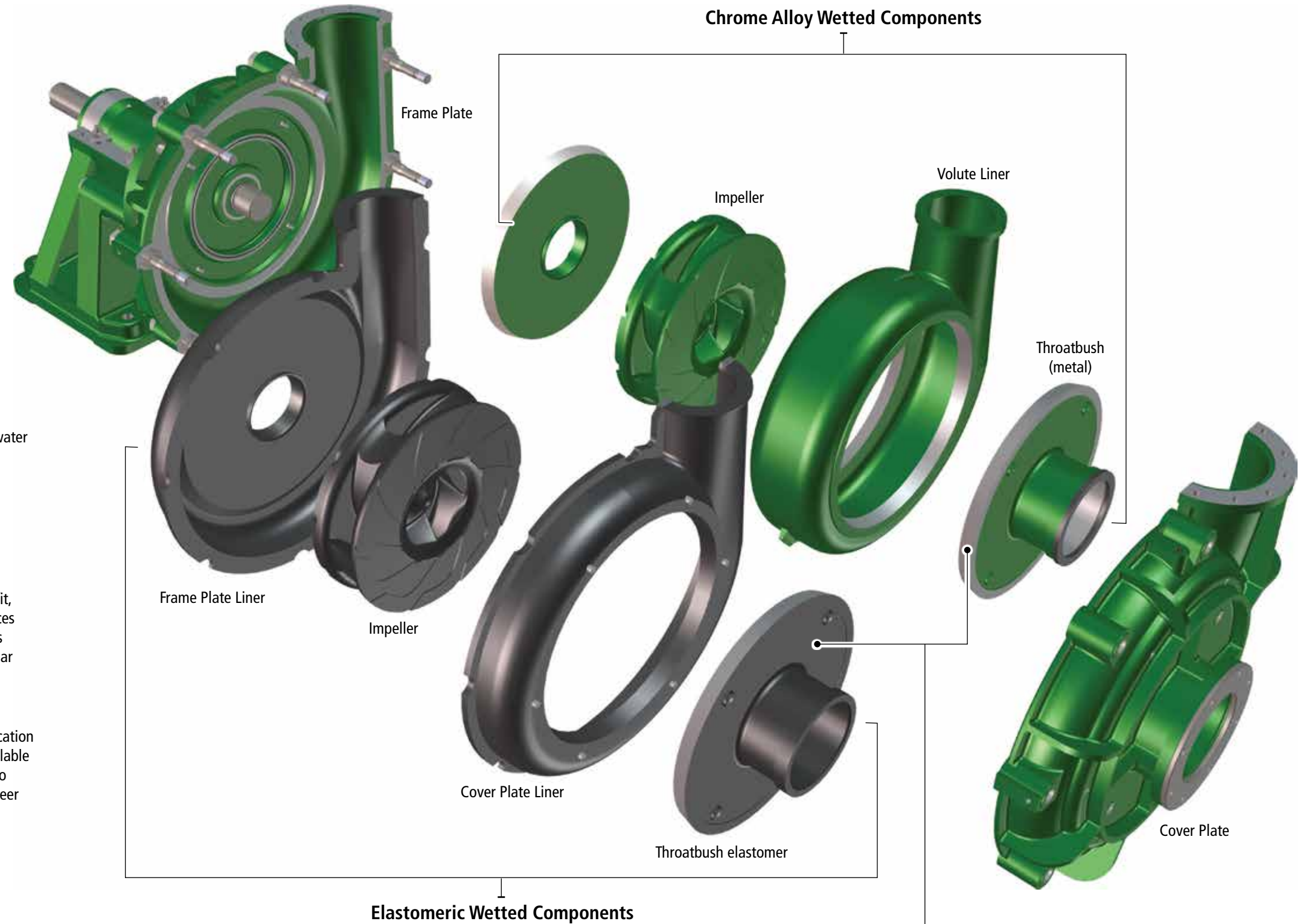

OUTER CASING

Heavy-duty cast iron cover and frame plates enclose the wet-end of the pump enabling high operating pressures.

MATERIAL SELECTION

Schurco Application Engineers can assist in specifying from a wide range of available chrome iron alloys and molded elastomers to optimize the wear characteristics of each component.

EASE OF MAINTENANCE

Tapered mating faces enable accurate alignment of liners

Basic Selection

S SERIES HYDRAULIC COVERAGE

All Models Available with Elastomer

Maximum Working Pressure:

Elastomer — 170 psi (1172 kPa)
 Chrome Iron — 300 psi (2068 kPa)

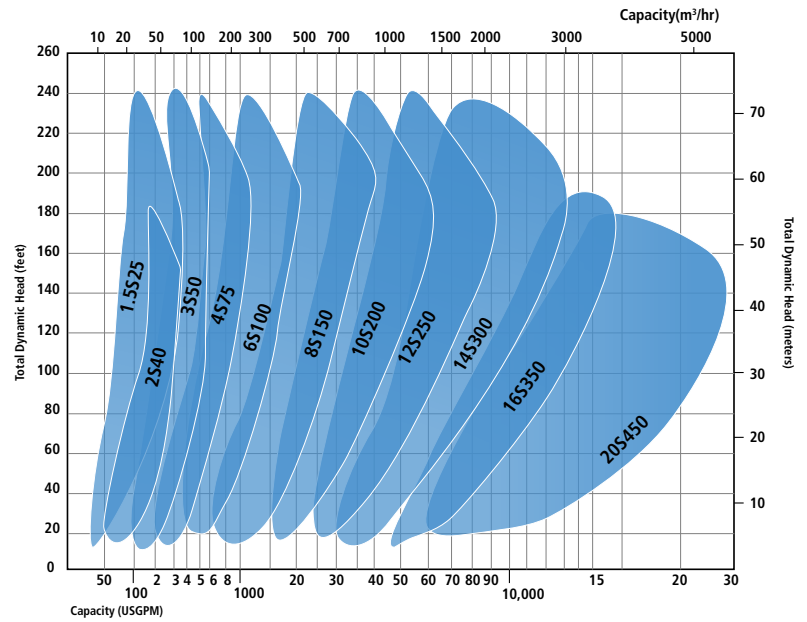

MATERIAL SELECTION

| | Liners | Impellers | Expeller | Stuffing Box Expeller Ring | Shaft Sleeve | Seals | Casing | Base |
|----------|---|---|---|--|--|----------------|--------------|--------------|
| Standard | Chrome Alloy* Natural Rubber | Chrome Alloy* Natural Rubber | Chrome Alloy* | Chrome Alloy* | 420C SS | Rubber Nitrile | Ductile Iron | Ductile Iron |
| Options | Proprietary Alloys Stainless Steels Duplex Alloys Hastelloy Neoprene Butyl EPDM Hypalon Nitrile | Proprietary Alloys Stainless Steels Duplex Alloys Hastelloy Neoprene Butyl EPDM Hypalon Nitrile | Ductile Iron Proprietary Alloys Stainless Steels Duplex Alloys Hastelloy Nat. Rubber | Natural Rubber Ductile Iron Proprietary Alloys Stainless Steels Duplex Alloys Hastelloy | CD4MCU 316 SS Hastelloy C Hard Coatings | Viton EPDM | N/A | N/A |

*Standard Chrome Alloy: ASTM A532 Class III Type A- 27% Cr; 650BHN; Alternatives available for highly corrosive services.



Schurco Hydraulic and Maintenance Training Seminar (Schurco 6x4 S Series natural rubber pump).



Schurco 8x6 S Series pumps at an industrial sand producer

Outline Dimensions

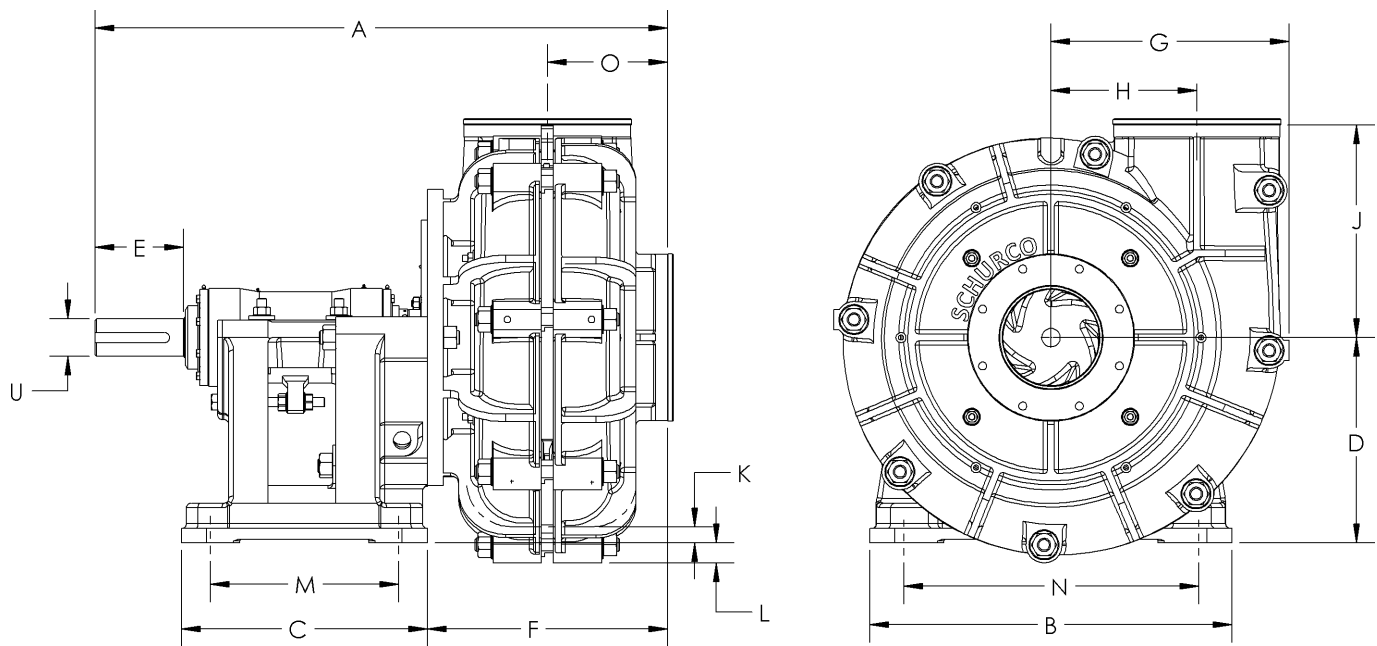

| Pump Model | A | B | C | D | U [mm] | Keyway [mm] | E | F | G | H | J | K | L | M | N | O | Weight (lb) | |
|-------------|-------|-------|-------|-------|--------|-------------|-------|-------|-------|-------|-------|------|-------|-------|-------|-------|-------------|--------|
| | | | | | | | | | | | | | | | | | Metal | Rubber |
| 1.5 S B. 25 | 22.95 | 11.61 | 9.76 | 7.76 | 28 | 8x7 | 3.11 | 8.11 | 7.13 | 3.86 | 6.73 | 1.81 | | 5.63 | 10.00 | 4.17 | 195 | 170 |
| 2 S B. 40 | 23.31 | 11.61 | 9.76 | 7.76 | 28 | 8x7 | 3.11 | 8.54 | 7.99 | 4.49 | 7.24 | 1.31 | | 5.63 | 10.00 | 4.49 | 345 | 260 |
| 3 S C. 50 | 30.24 | 15.98 | 12.24 | 10.00 | 42 | 12x8 | 4.76 | 11.02 | 9.37 | 5.43 | 8.27 | 2.81 | | 6.89 | 14.02 | 5.94 | 435 | 340 |
| 4 S C. 75 | 33.19 | 15.98 | 12.24 | 10.00 | 42 | 12x8 | 4.76 | 13.90 | 11.50 | 5.87 | 10.31 | 0.93 | | 6.89 | 14.02 | 7.36 | 550 | 500 |
| 4 S D. 75 | 37.13 | 19.37 | 14.33 | 12.99 | 65 | 18.x11 | 6.46 | 13.90 | 11.50 | 5.87 | 10.31 | 3.94 | | 8.39 | 17.01 | 7.36 | 700 | 640 |
| 6 S D 100 | 40.20 | 19.37 | 14.33 | 12.99 | 65 | 18.x11 | 6.46 | 16.69 | 15.98 | 9.02 | 13.31 | 0.43 | | 8.39 | 17.01 | 8.62 | 1,475 | 1,000 |
| 6 S E 100 | 46.38 | 24.49 | 17.64 | 17.99 | 80 | 22.x14 | 8.74 | 17.05 | 15.98 | 9.02 | 13.31 | 5.43 | | 10.12 | 21.50 | 8.62 | 1,950 | 1,400 |
| 8 S E 150 | 51.26 | 24.49 | 17.64 | 17.99 | 80 | 22.x14 | 8.74 | 21.93 | 21.69 | 12.52 | 18.11 | | 2.44 | 10.12 | 21.50 | 11.50 | 3,300 | 2,165 |
| 8 S F 150 | 59.33 | 33.74 | 24.96 | 24.02 | 100 | 28.x16 | 10.98 | 21.22 | 21.69 | 12.52 | 18.11 | 3.54 | | 13.74 | 30.00 | 11.50 | 4,000 | 3,065 |
| 10 S F 200 | 64.80 | 39.02 | 27.76 | 24.02 | 100 | 28.x16 | 10.98 | 26.89 | 26.50 | 16.50 | 25.00 | | 0.47 | 21.42 | 30.00 | 13.11 | 7,040 | 5,270 |
| 10 S S 200 | 68.82 | 45.28 | 30.71 | 25.59 | 120 | 32.x18 | 11.02 | 27.24 | 26.50 | 16.50 | 25.00 | 1.06 | | 24.41 | 35.43 | 13.11 | 8,250 | 6,480 |
| 12 S F 250 | 67.76 | 39.02 | 27.76 | 24.02 | 100 | 28.x16 | 10.98 | 29.65 | 29.72 | 18.27 | 26.50 | | 4.09 | 25.20 | 29.92 | 15.00 | 9,250 | 7,030 |
| 12 S S 250 | 71.50 | 45.28 | 30.71 | 25.59 | 120 | 32.x18 | 11.02 | 30.00 | 29.72 | 18.27 | 26.50 | | 2.56 | 24.41 | 35.43 | 15.00 | 10,250 | 8,150 |
| 14 S F 300 | 69.76 | 39.02 | 27.76 | 24.02 | 100 | 28.x16 | 10.98 | 31.61 | 36.89 | 24.76 | 32.76 | | 10.35 | 21.42 | 30.00 | 15.98 | 12,890 | 9,300 |
| 14 S S 300 | 73.74 | 45.28 | 30.71 | 25.59 | 120 | 32.x18 | 11.02 | 31.97 | 36.89 | 24.76 | 32.76 | | 8.82 | 24.41 | 35.43 | 15.98 | 14,100 | 10,300 |
| 16 S G 350 | 86.26 | 47.52 | 34.49 | 33.50 | 140 | 36.x20 | 14.49 | 40.00 | 37.24 | 33.86 | 35.00 | | 3.74 | 29.49 | 33.50 | 17.76 | 22,000 | 17,000 |
| 16 S T 350 | 91.34 | 57.48 | 41.34 | 35.43 | 150 | 36.x20 | 13.76 | 37.52 | 41.26 | 25.98 | 35.00 | | 3.31 | 33.86 | 47.24 | 17.76 | 22,000 | 17,000 |
| 20 S T 450 | 97.13 | 57.48 | 41.34 | 35.43 | 150 | 36.x20 | 13.78 | 43.31 | 55.67 | 37.01 | 48.43 | | 16.42 | 33.86 | 47.24 | 22.83 | 38,300 | 28,100 |

All dimensions in inches except keyway and shaft diameter "U" which are in [mm]

Dimensions shown in the table are only for reference and evaluation purposes.
Please refer only to certified drawings for construction and arrangement purposes.

16 S 3500

SCHURCO



9410 Florida Mining Boulevard E.
Jacksonville, Florida 32257
904.356.6840
schurcoslurry.com